

REVISION HISTORY			
REV	DESCRIPTION	DATE	APPROVED

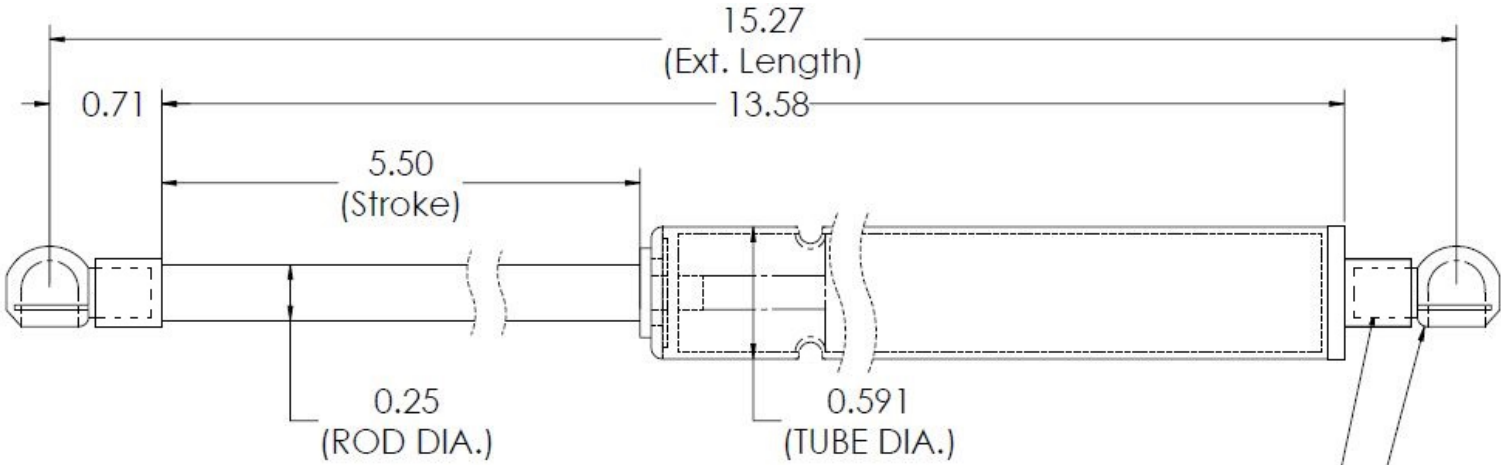

Thread: M6 (2 places)

Metal End Fittings: MT1 (2 places)

NOTES:

1. MATERIAL : CYLINDER - HEAVY GAUGE STEEL, BLACK POWDERCOAT PAINT
ROD - HARDENED STEEL, BLACK NITRIDE
2. FORCE : 20 POUNDS
3. DIMENSIONS ASSUMING END CONNECTORS ARE FULLY SCREWED INTO PLACE
4. DRAWING LENGTHS (NOT DIMENSIONED) OF CYLINDER AND ROD BODIES ARE NOT TO SCALE

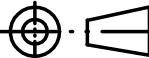
 NUOMENG		NAME	DATE
		DRAWN Boytcho	31/07/18
<small>THIS DOCUMENT AND ITS CONTENTS ARE THE PROPERTY OF NUOMENG. THIS DOCUMENT CONTAINS CONFIDENTIAL PROPRIETARY INFORMATION. THE REPRODUCTION, DISTRIBUTION, UTILISATION OR THE COMMUNICATION OF THIS DOCUMENT OR ANY PART THEREOF, WITHOUT EXPRESS AUTHORIZATION IS STRICTLY FORBIDDEN.</small>		DWG NO	REV
		NSG1527S20MT1	0
<small>REMOVE ALL BURRS & BREAK ALL SHARP EDGES</small>		TITLES	SCALE
		GAS SPRING -	N.T.S.
<small>ALL DIMENSIONS ARE IN INCHES UNLESS OTHERWISE SPECIFIED</small>		TOLERANCES	THIRD ANGLE PROJECTION
		XX ±0.060 XXX ±0.030 XXXX ±0.015 ANGLES ±1.0° HOLES ±0.005	 SHEET 1 OF 1
<small>SIZE</small>		B	