

| REVISION HISTORY |             |      |          |
|------------------|-------------|------|----------|
| REV              | DESCRIPTION | DATE | APPROVED |
|                  |             |      |          |

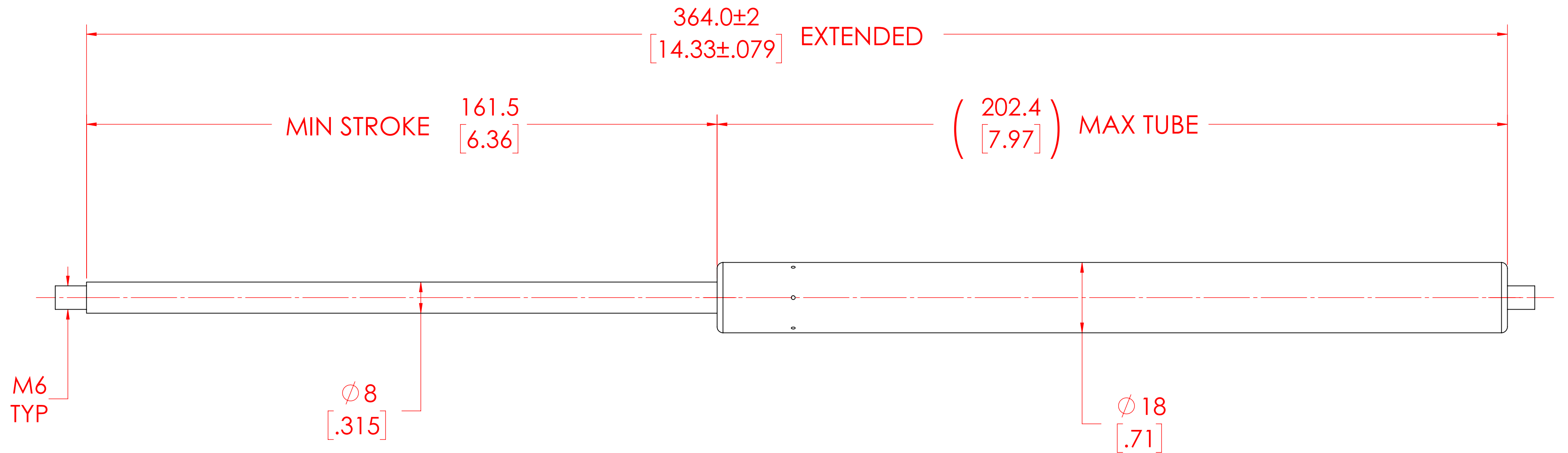

| FORCES (STATICALLY MEASURED) |    |
|------------------------------|----|
| F1                           | F2 |
| 60 LBS (267 N) +10%<br>-5%   | -  |

**NOTES:**

- 1) MATERIAL: CYLINDER - STEEL, BLACK PAINT / ROD - STEEL BLACK NITRIDE.
- 2) OPERATING TEMPERATURE: -40°C TO +80°C.
- 3) STANDARD PART IDENTIFICATION TO INCLUDE PART NUMBER, DATE CODE AND WARNING MESSAGE. LABEL NOT TO BE REMOVED
- 4) GAS SPRING IS SUGGESTED TO BE MOUNTED SHAFT DOWN (ROD DOWN) FOR MAXIMUM PERFORMANCE.
- 5) END FITTINGS TO BE ORIENTED AS SHOWN ±5°.
- 6) GAS SPRINGS WILL BE SEALED IN CLEAR PLASTIC BAGS TO AVOID DAMAGE, DUST, OR OTHER FOREIGN OBJECTS.
- 7) GAS SPRING TO BE ASSEMBLED WITH END FITTINGS COMPLETELY FASTENED.
- 8) GREASE TO BE INCLUDED INSIDE THE BALL SOCKET OF THE END FITTINGS

|  |  |              |                            |            |       |
|--|--|--------------|----------------------------|------------|-------|
| <b>NORMONT</b>   | NAME   | MABR         | DATE                       | 01/18/2024 |       |
|  | DRAWN  |              |                            |            |       |
|  | CHECKED  |              |                            |            |       |
|  | PART No.   | NSG1575M60   |                            | REV        | -     |
| THIS DOCUMENT AND ITS CONTENTS ARE THE PROPERTY OF NORMONT<br>THIS DOCUMENT CONTAINS CONFIDENTIAL PROPRIETARY INFORMATION. THE REPRODUCTION, DISTRIBUTION, UTILISATION OR THE COMMUNICATION OF THIS DOCUMENT OR ANY PART THEREOF, WITHOUT EXPRESS AUTHORISATION IS STRICTLY FORBIDDEN. | TITLE  |              |                            | GAS SPRING |       |
|  | TOLERANCES   |              | THIRD ANGLE PROJECTION<br> | SCALE      | 1.3:1 |
|  | XX   | ± 0.060      |                            | SIZE       | C     |
|  | X.XX   | ± 0.030      |                            |            |       |
|  | X.XXX  | ± 0.010      |                            |            |       |
| ANGLES   | ± 1°   | SHEET 1 OF 1 |                            |            |       |
| HOLES  | ± 0.005  |              |                            |            |       |
| REMOVE ALL BURRS AND BREAK ALL SHARP EDGES   | ALL DIMENSIONS ARE DUAL UNLESS OTHERWISE SPECIFIED |              |                            |            |       |