

REVISION HISTORY			
REV	DESCRIPTION	DATE	APPROBED
1	FORCE TOLERANCES ADDED	07/12/2023	CSH
2	DUST CAP ADDED	01/25/2024	JACN
3			

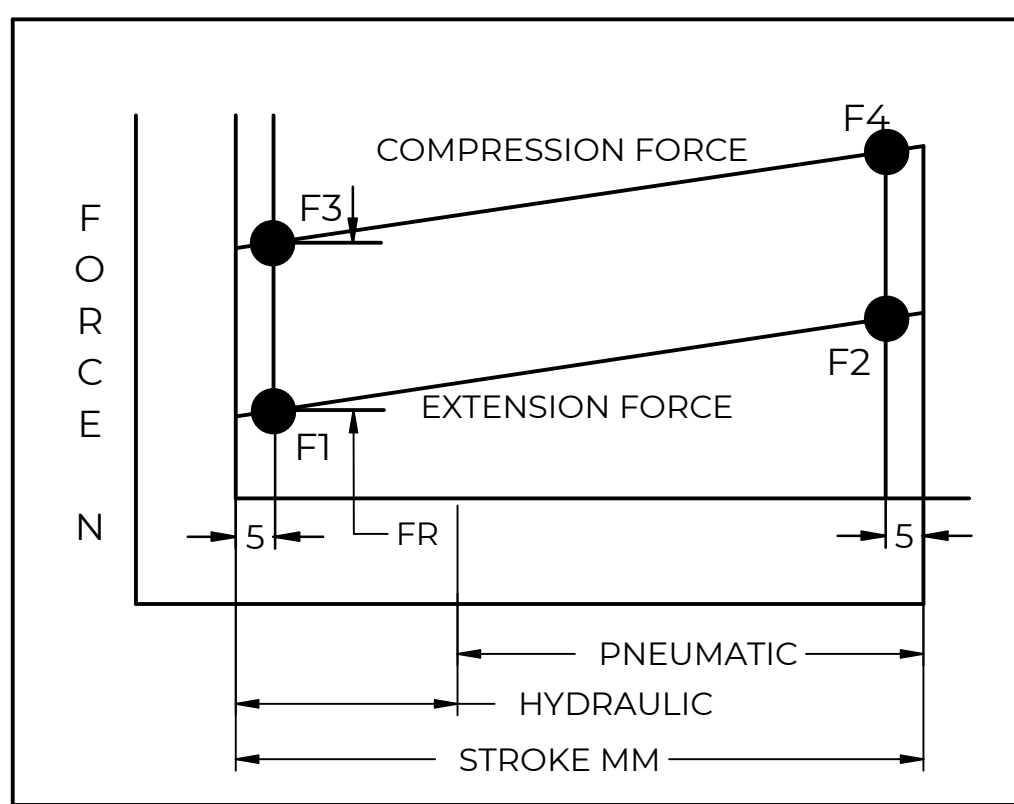
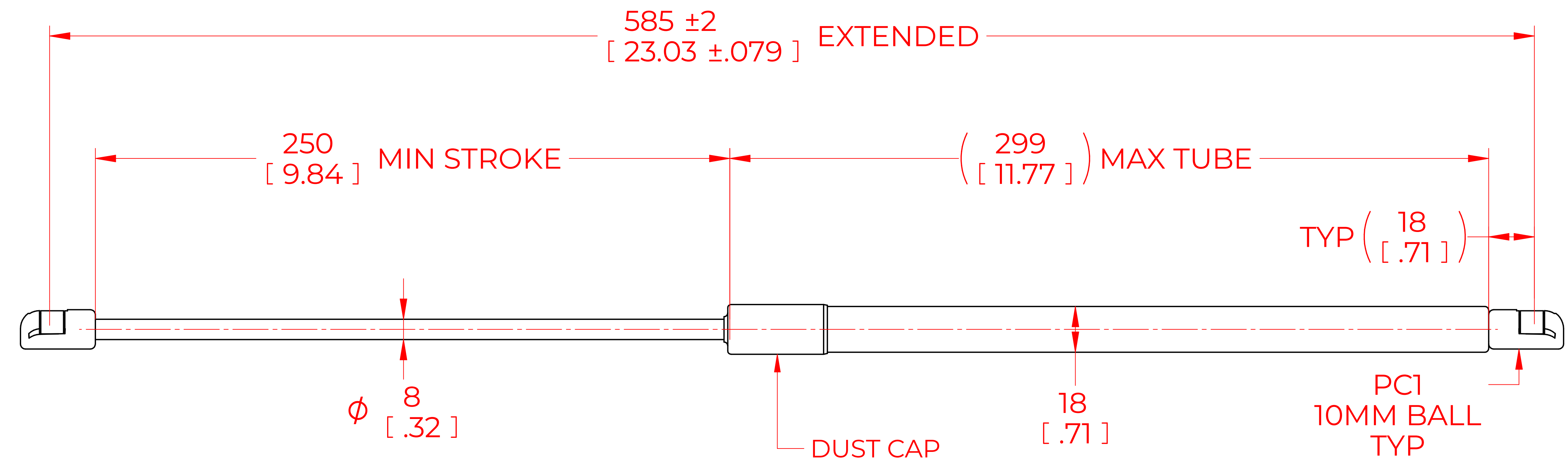

FORCES (STATICALLY MEASURED)	
F1	F2
90 LBS (400 N) +10% -5%	

- NOTES:**
- 1) MATERIAL: CYLINDER - HEAVY GAUGE STEEL, BLACK PAINT. ROD - HARDENED STEEL BLACK NITRIDE.
 - 2) OPERATING TEMPERATURE: -40°C TO +80°C.
 - 3) STANDARD LABEL TO INCLUDE PART NUMBER, DATE CODE AND WARNING MESSAGE. LABEL NOT TO BE REMOVED.
 - 4) GAS SPRING NOT TO BE CHANGED OR MODIFIED FROM ITS ORIGINAL MANUFACTURED INTENT.
 - 5) GAS SPRING IS SUGGESTED TO BE MOUNTED SHAFT DOWN (ROD DOWN) FOR MAXIMUM PERFORMANCE.
 - 6) CONNECTORS TO BE ORIENTED AS SHOWN ±5°.
 - 7) GAS SPRINGS WILL BE SEALED IN CLEAR PLASTIC BAGS TO AVOID DAMAGE, DUST, OR OTHER FOREIGN OBJECTS.
 - 8) GAS SPRING TO BE ASSEMBLED WITH END FITINGS COMPLETELY FASTENED.
 - 9) GAS SPRINGS ARE NOT TO BE OPENED.
 - 10) GREASE TO BE INCLUDED INSIDE THE BALL SOCKET OF THE END FITTINGS.

NORMONT	DRAWN	NAME	DATE
	CHECKED	CSH	03/30/2023
THIS DOCUMENT AND ITS CONTENTS ARE THE PROPERTY OF NORMONT THIS DOCUMENT CONTAINS CONFIDENTIAL PROPRIETARY INFORMATION. THE REPRODUCTION, DISTRIBUTION, UTILISATION OR THE COMMUNICATION OF THIS DOCUMENT OR ANY PART THEREOF, WITHOUT EXPRESS AUTHORISATION IS STRICTLY FORBIDDEN.	PART No.		REV
	NSG2303M90PC1		2
	TITLE		
REMOVE ALL BURRS AND BREAK ALL SHARP EDGES	ALL DIMENSIONS ARE DUAL UNLESS OTHERWISE SPECIFIED	TOLERANCES	
		X.X	± 0.060
		X.XX	± 0.030
		X.XXX	± 0.010
		ANGLES	± 1°
		THIRD ANGLE PROJECTION	SCALE
			1:1
			SIZE
		SHEET 1 OF 1	