

| REVISION HISTORY |  |            |          |
|------------------|--|------------|----------|
| REV              | DESCRIPTION                              | DATE       | APPROVED |
| 1                | TEMPLATE UPDATED. FORCE TOLERANCE ADDED. | 02/01/2024 | JACN     |

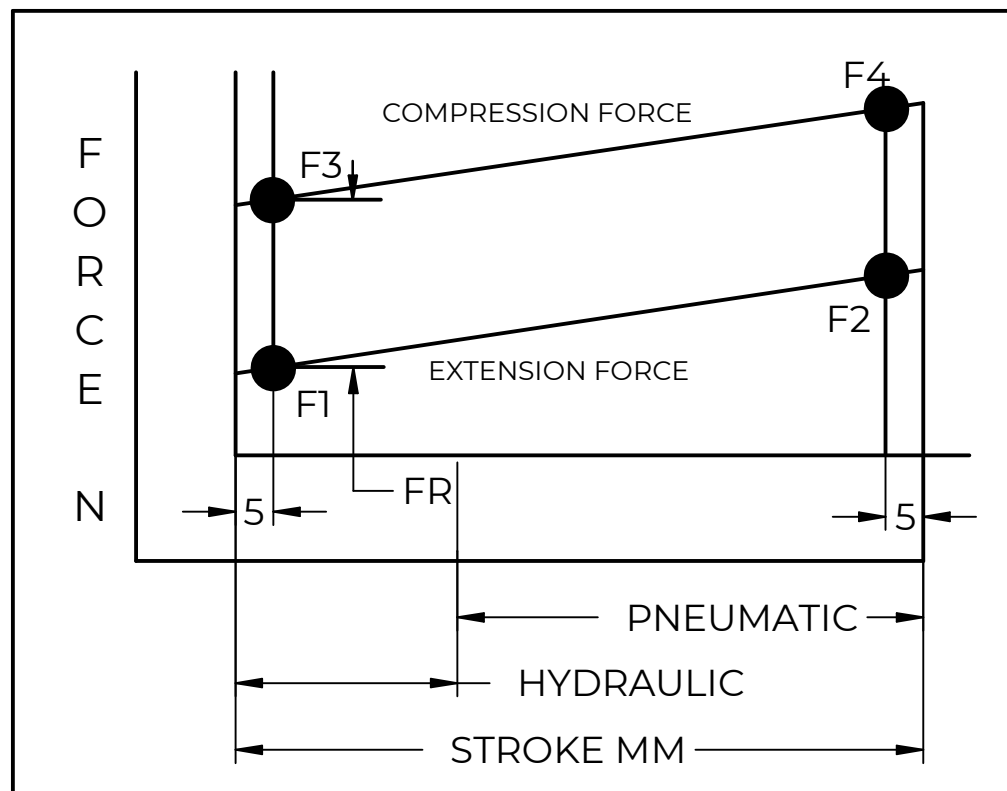
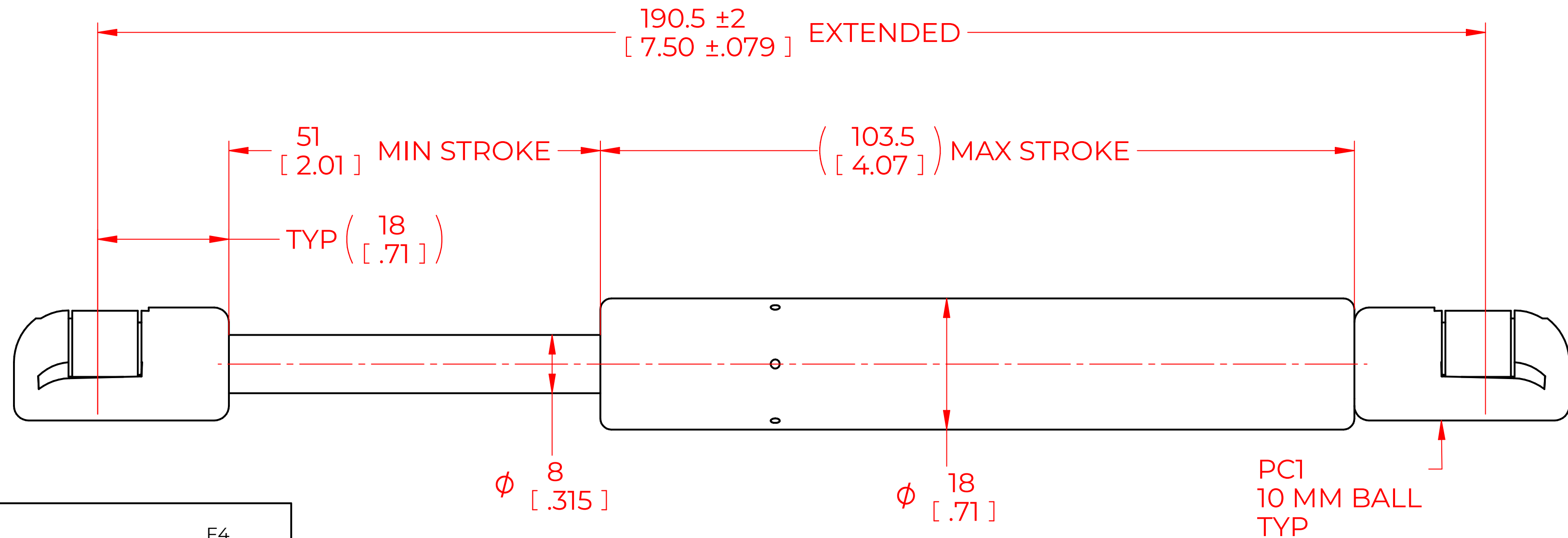

| FORCES (STATICALLY MEASURED)                  |      |
|---|------|
| F1  | (F2) |
| 40 LBS (178 N) <sup>+10%</sup> <sub>-5%</sub> | -    |

**NOTES:**

- 1) MATERIAL: CYLINDER - STEEL, BLACK PAINT / ROD - STEEL BLACK NITRIDE.
- 2) OPERATING TEMPERATURE: -40°C TO +80°C.
- 3) STANDARD PART IDENTIFICATION TO INCLUDE PART NUMBER, DATE CODE AND WARNING MESSAGE. LABEL NOT TO BE REMOVED.
- 4) GAS SPRING IS SUGGESTED TO BE MOUNTED SHAFT DOWN (ROD DOWN) FOR MAXIMUM PERFORMANCE.
- 5) END FITTINGS TO BE ORIENTED AS SHOWN ±5°.
- 6) GAS SPRINGS WILL BE SEALED IN CLEAR PLASTIC BAGS TO AVOID DAMAGE, DUST, OR OTHER FOREIGN OBJECTS.
- 7) GAS SPRING TO BE ASSEMBLED WITH END FITTINGS COMPLETELY FASTENED.
- 8) GREASE TO BE INCLUDED INSIDE THE BALL SOCKET OF THE END FITTINGS.

|  |              |              |                        |
|--|--------------|--------------|------------------------|
| <b>NORMONT</b>   | DRAWN        | NAME         | DATE                   |
|  | CHECKED      | CSH          | 05/17/2023             |
| THIS DOCUMENT AND ITS CONTENTS ARE THE PROPERTY OF NORMONT<br>THIS DOCUMENT CONTAINS CONFIDENTIAL PROPRIETARY INFORMATION. THE REPRODUCTION, DISTRIBUTION, UTILISATION OR THE COMMUNICATION OF THIS DOCUMENT OR ANY PART THEREOF, WITHOUT EXPRESS AUTHORISATION IS STRICTLY FORBIDDEN. | PART No.     |              | REV                    |
|  | NSG750M40PC1 |              |                        |
|  | TITLE        |              |                        |
|  | GAS SPRING   |              |                        |
| REMOVE ALL BURRS AND BREAK ALL SHARP EDGES   | TOLERANCES   |              | THIRD ANGLE PROJECTION |
|  | X.X          | ± 0.060      |                        |
|  | X.XX         | ± 0.030      | SCALE                  |
|  | X.XXX        | ± 0.010      |                        |
| ALL DIMENSIONS ARE DUAL UNLESS OTHERWISE SPECIFIED   |              | SHEET 1 OF 1 | SIZE                   |
| ANGLES ± 1°  |              |              |                        |
| HOLES ± 0.005  |              |              |                        |