

REVISION HISTORY			
REV	DESCRIPTION	DATE	APPROVED
1	TEMPLATE UPDATED. FORCE TOLERANCE ADDED.	02/01/2024	JACN

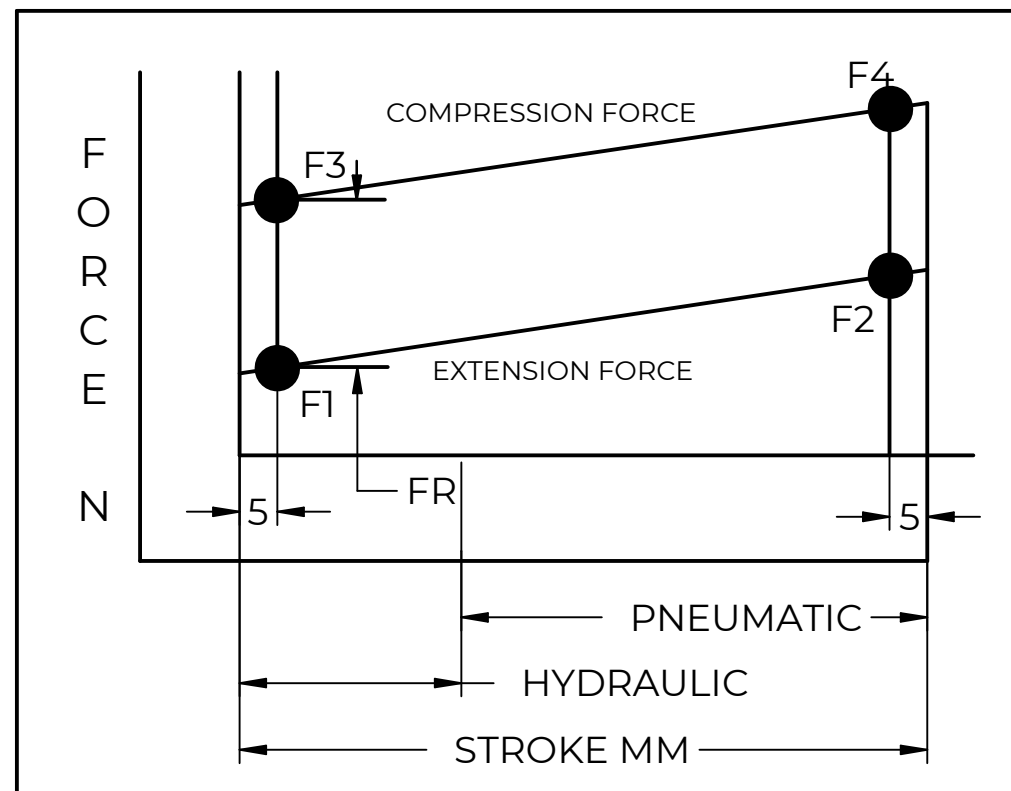
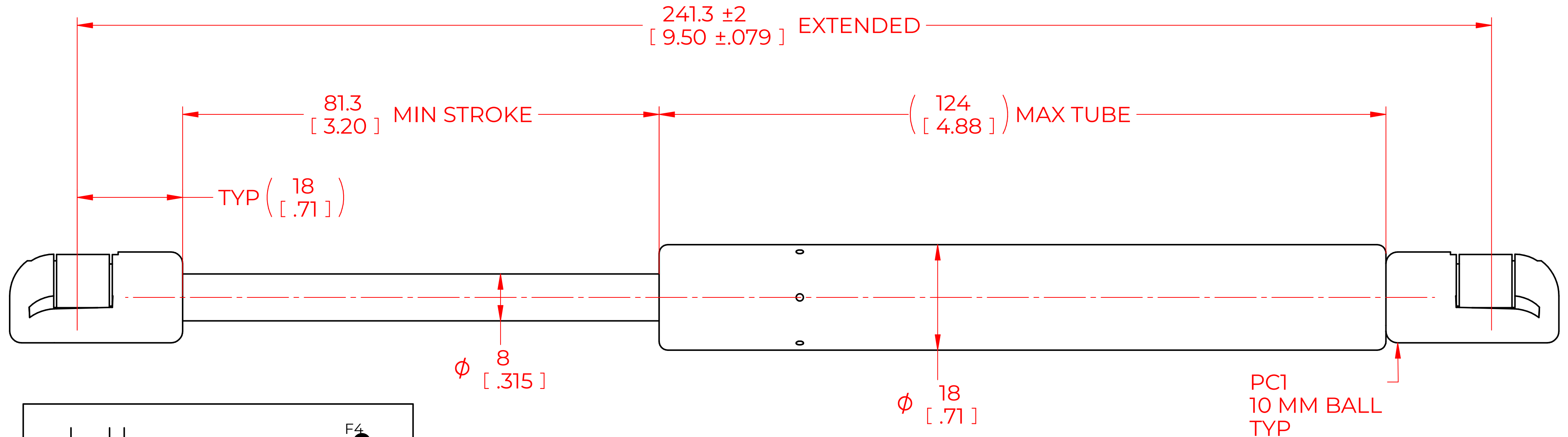

FORCES (STATICALLY MEASURED)	
F1	(F2)
150 LBS (667 N) ^{+10%} _{-7%}	-

NOTES:

- 1) MATERIAL: CYLINDER - STEEL, BLACK PAINT / ROD - STEEL BLACK NITRIDE.
- 2) OPERATING TEMPERATURE: -40°C TO +80°C.
- 3) STANDARD PART IDENTIFICATION TO INCLUDE PART NUMBER, DATE CODE AND WARNING MESSAGE. LABEL NOT TO BE REMOVED
- 4) GAS SPRING IS SUGGESTED TO BE MOUNTED SHAFT DOWN (ROD DOWN) FOR MAXIMUM PERFORMANCE.
- 5) END FITTINGS TO BE ORIENTED AS SHOWN ±5°.
- 6) GAS SPRINGS WILL BE SEALED IN CLEAR PLASTIC BAGS TO AVOID DAMAGE, DUST, OR OTHER FOREIGN OBJECTS.
- 7) GAS SPRING TO BE ASSEMBLED WITH END FITTINGS COMPLETELY FASTENED.
- 8) GREASE TO BE INCLUDED INSIDE THE BALL SOCKET OF THE END FITTINGS.

NORMONT		NAME	DATE
DRAWN	CSH		05/17/2023
CHECKED			
THIS DOCUMENT AND ITS CONTENTS ARE THE PROPERTY OF NORMONT		PART No.	NSG950MPC1
THIS DOCUMENT CONTAINS CONFIDENTIAL PROPRIETARY INFORMATION. THE REPRODUCTION, DISTRIBUTION, UTILISATION OR THE COMMUNICATION OF THIS DOCUMENT OR ANY PART THEREOF, WITHOUT EXPRESS AUTHORISATION IS STRICTLY FORBIDDEN.		TITLE	GAS SPRING
REMOVE ALL BURRS AND BREAK ALL SHARP EDGES		TOLERANCES	
		X.X	± 0.060
		X.XX	± 0.030
		X.XXX	± 0.010
ALL DIMENSIONS ARE DUAL UNLESS OTHERWISE SPECIFIED		THIRD ANGLE PROJECTION	SCALE
			2:1
		ANGLES	± 1°
		HOLES	± 0.005
		SHEET 1 OF 1	
		SIZE	
		C	