

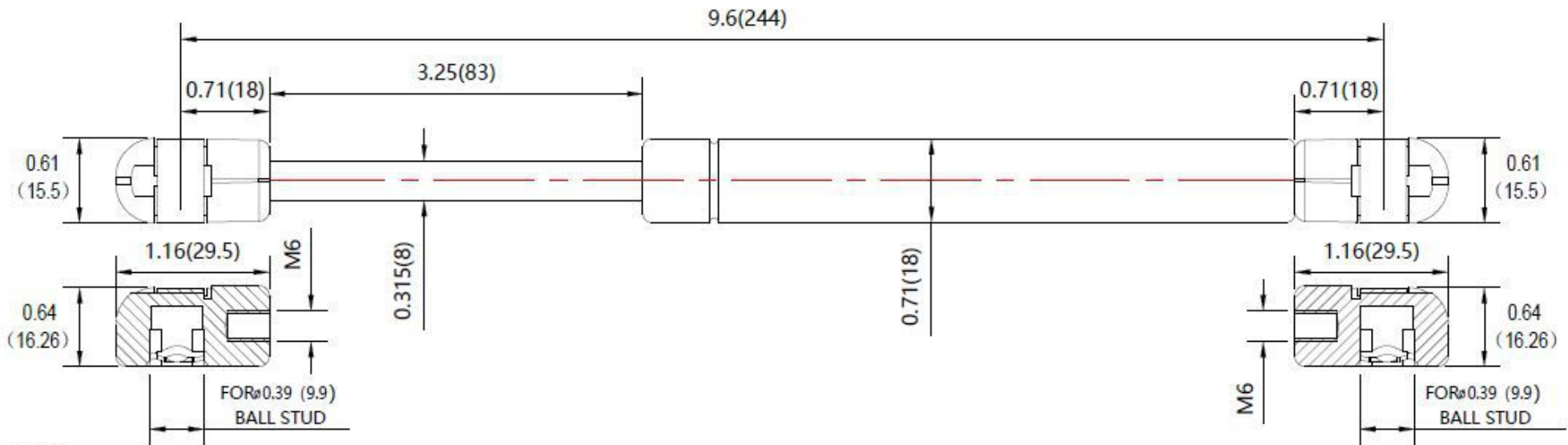

REVISION HISTORY			
REV	DESCRIPTION	DATE	APPROVED



NOTES

1. MATERIAL : CYLINDER - HEAVY GAUGE STEEL , BLACK POWDERCOAT PAINT
ROD - HARDENED STEEL BLACK NITRIDE
2. FORCE: 80LBS/ 356N
3. DIMENSIONS ASSUMING END CONNECTORS ARE FULLY SCREWED INTO PLACE
4. DRAWING LENGTHS (NOT DIMENSIONED) OF CYLINDER AND ROD BODIES ARE NOT TO SCALE
5. OPERATING TEMPERATURE : - 30 C TO + 80 C
6. Label to include part number , date code , and warning message Label not to be remove
7. Gas Spring not to be modified , or changed from manufactured , original , product
8. Gas Spring to is suggested to be mounted shaft down (rod down) for maximum performance
9. Connectors to be lined up per drawing . 5 degree deviation permitted
10. Gas Springs will be individually packed in sealed clear plastic bags , to avoid damage , dust , or other foreign material - objects
11. Gas Spring to be assembled per the drawing with end fittings assembled / fastened
12. Gas Springs are not to be opened
13. Inside of each end fitting to be greased

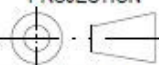
	NAME	DATE	
	Allen	12/13/19	
<small>THIS DOCUMENT AND ITS CONTENTS ARE THE PROPERTY OF NUOMENG. THIS DOCUMENT CONTAINS CONFIDENTIAL PROPRIETARY INFORMATION. THE REPRODUCTION, DISTRIBUTION, UTILISATION OR THE COMMUNICATION OF THIS DOCUMENT OR ANY PART THEREOF, WITHOUT EXPRESS AUTHORIZATION IS STRICTLY FORBIDDEN.</small>	DWG NO	REV	
	NSG960M80PC1	0	
	TITLE Gas Spring		
REMOVE ALL BURRS & BREAK ALL SHARP EDGES ALL DIMENSIONS ARE IN inch UNLESS OTHERWISE SPECIFIED	TOLERANCES	THIRD ANGLE PROJECTION	SCALE
	X.X ±0.060		N.T.S.
	X.XX ±0.030		SIZE
	X.XXX ±0.015		B
	ANGLES ±1.0°		
HOLES ±0.005	SHEET 1 OF 1		