

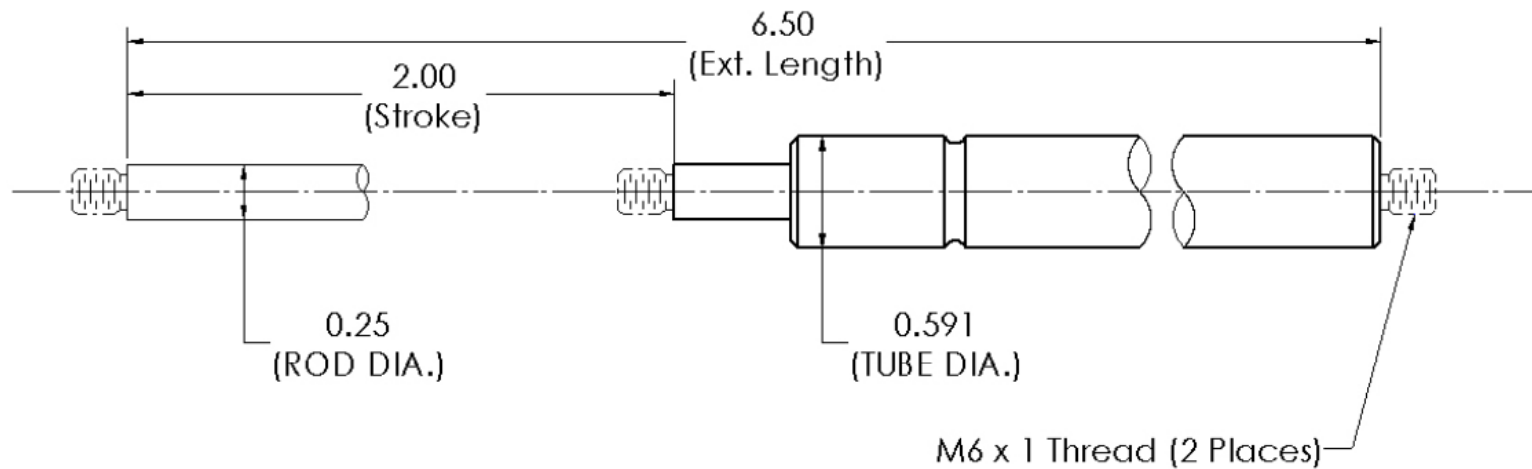

REVISION HISTORY			
REV	DESCRIPTION	DATE	APPROVED



NOTES:

1. MATERIAL : CYLINDER - HEAVY GAUGE STEEL, BLACK POWDERCOAT PAINT  
ROD - HARDENED STEEL, BLACK NITRIDE
2. FORCE : Compression Damper Heavy.
3. DIMENSION: Ext. Length dimension without end fittings. Need to add end fittings length.
4. DRAWING LENGTHS (NOT DIMENSIONED) OF CYLINDER AND ROD BODIES ARE NOT TO SCALE.

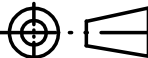
 <b>NUOMENG</b>		NAME	DATE
		DRAWN Hamza Tariq	17/10/18
<small>THIS DOCUMENT AND ITS CONTENTS ARE THE PROPERTY OF NUOMENG. THIS DOCUMENT CONTAINS CONFIDENTIAL PROPRIETARY INFORMATION. THE REPRODUCTION, DISTRIBUTION, UTILISATION OR THE COMMUNICATION OF THIS DOCUMENT OR ANY PART THEREOF, WITHOUT EXPRESS AUTHORIZATION IS STRICTLY FORBIDDEN.</small>		DWG NO	REV
		NSDC650SH	0
<small>REMOVE ALL BURRS &amp; BREAK ALL SHARP EDGES</small>		TITLE	
		Compression Damper Heavy	
<small>ALL DIMENSIONS ARE IN INCHES UNLESS OTHERWISE SPECIFIED</small>		TOLERANCES	THIRD ANGLE PROJECTION
		XX ±0.060 XXX ±0.030 XXXX ±0.015 ANGLES ±1.0° HOLES ±0.005	
		SCALE	SIZE
		N.T.S.	B
		SHEET 1 OF 1	